

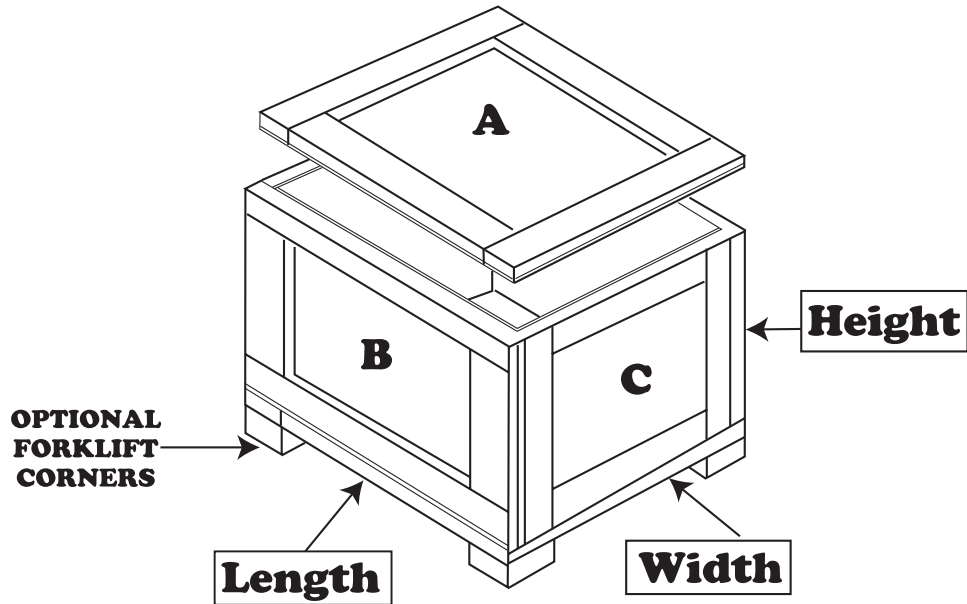

WOODEN CRATES ORDER FORM

Fax all orders to: (305) 722-0111
Lead time on all orders is 3 working days.

PLEASE FILL OUT THIS WORKSHEET TO ORDER YOUR CRATES



Please complete the following when ordering wooden crates:

1. What are the inside dimensions of the crate? Length _____" Width _____" Height _____"
2. Add 2" to the Length, 2" to the Width and 7" to the Height to get the new outside Length, Width and Height.
3. Fill in the new outside dimensions of the crate: Length _____" Width _____" Height _____"
(+2") (+2") (+7")
4. Multiply the L x W x H and divide by 1728 to determine the cubic feet of the crate:

$$\frac{\quad}{L} \times \frac{\quad}{W} \times \frac{\quad}{H} = \frac{\quad}{\quad} / 1728 = \frac{\quad}{\quad} \text{ Cubic Feet}$$

5. Multiply the cubic feet by the rate: $\frac{\quad}{\text{Cubic Feet}} \times \$2.45 = \$ \frac{\quad}{\text{Your Cost}}$

6. COMPARE your cost above to the minimum Crate Rate of \$100.00. Your cost is the **greater** of the two.
7. What is the weight of the item being crated? _____ lbs
8. Do you want the optional forklift entry corners? _____ YES _____ NO
9. Please indicate which panel is to be the opening panel by circling **A**, **B**, or **C** on the diagram above.

STORE # _____

PHONE # _____

NAME _____

PO # _____